



The 75mm Louvre System Range

The basic requirement for a louvre is to move air in and around a building, thereby creating added comfort and convenience for better living. ALU+ louvres come in various blade types and numerous frame choices that allow their usage as an integral part of a windows system or separately as a stand-alone louvre.

Blades and frame are made from extruded aluminium for greater strength and accuracy. The system is ingeniously designed for simple self-assembly from standard bar length profiles.

ALU+ has developed a range of louvres with high performance and aesthetic appeal in mind. This for domestic and industrial use.

Louvre panels are available in various configurations and finishes.

Louvre panels can be supplied ready made or in bar length format. (easy assembly)

ALU+ has experience in making louvres in irregular and unusual shapes such as circular and triangular.



Here are just three of the many different colours and Naturally Anodised finishes that are available



This is an example of one of the many types of Louvres supplied by Alu-Plus. It was supplied fully assembled and powder-coated, ready for fitment to the building



Our Louvres are made to measure to any size that suits your requirements. As you can see, they don't have to be rectangular.

We can even produce round ones!



Security Louvres

This is a new option **available on all our standard louvre ranges**. Its ingenious design means that it is a cost effective solution to a common problem

Choosing this option ensures that the **individual louvre blades can not be removed after assembly** but the **panels can be removed** for replacement or maintenance by gaining access to the normal fitting points



On the left is a section of our standard Louvre
The blades are removable in case of damage

On the right is a section of our Security Louvre
The Blades can not be removed after assembly



Round Louvres and Other Shapes

One of the products unique to Alu-Plus is the **Round Louvre**

We can produce Louvres like the one below with a Minimum Diameter of 400mm, all in a single piece. All other design aspects are as per our Flanged Louvre range

A variation on this is the **Arched Louvre**

We can also produce Triangular Louvres, and virtually any Trapezoidal shape as well

Contact us now for further information



Round Louvre Specifications:

- Minimum Diameter = 400mm
- 34mm Flanged Louvre Design

Technical details

- Aluminium blade profiles are clipped into aluminium blade support clips.
- Blade pitch: 34mm.
- Blade height: 39mm.
- Depth to fit: 30,6mm.
- Total depth: 36mm.
- Visual free area : 68%.

Finishing

Natural anodised: 15 to 22 micron.

Other shades possible.

Powder coated in any RAL finish: 60 – 80 micron.

Manufacture

- Made to measure.
- A reinforcement profile carrying extra blade supports is fitted when the width of the louvre is > 700mm.
- A fibre glass insect mesh is fitted to the back as standard
- Stainless Steel and Gas meshes can be fitted as an option



Flanged Louvre LLS75-FL

Type

Built-in louvre flanged with a flanged frame profile and a pitch of 75 mm. All profiles are manufactured from aluminium extrusions with Z-shaped louvres

Technical details

- All parts (frame profile, clips and blades) are manufactured from aluminium extrusions Al Mg Si 0,5
- Aluminium louvre clips are fitted into the frame profile.
- Aluminium louvre blades are clipped into the louvre clips
- Blade pitch: 75mm.
- Blade height: 107mm.
- Depth to fit: 88mm.
- Flange as required, typically 38mm.
- Visual free area : 72%.
- Profile thickness: Minimum 1.5mm.

Finishing

Natural anodised: 15 to 22 micron.

Other shades possible.

Powder coated in any RAL finish: 60 – 80 micron.

10 Year guarantee on Colour Fastness

Manufacture

- Made to measure.
- Bar length profile for self assembly.
- A reinforcement profile carrying extra blade supports is fitted when the width of the louvre is > 700mm.
- Nylon insect mesh is fitted to the back as standard
- Stainless Steel and Gas meshes can be fitted as an option

Options

- For an improved water tightness, an aluminium water drainage profile can be fitted at the bottom of the louvre. This is to ensure better water tightness.

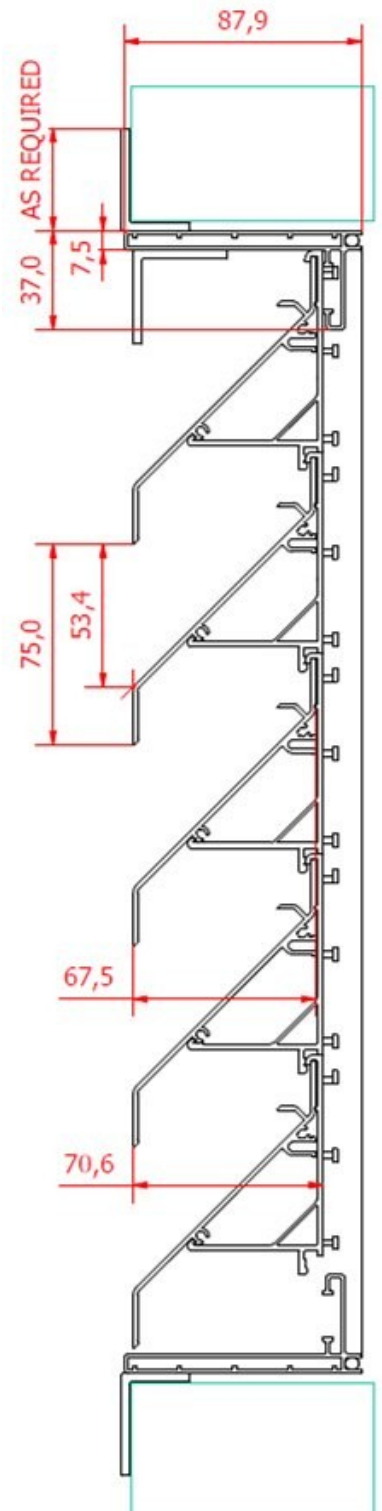



Glazed-In Louvre: LLS75-GL28

Type

- 75mm Glazed-in Louvre for 28mm Glazing

Technical details

- Aluminium blade profiles are clipped into aluminium blade support clips.
- Blade pitch: 50mm.
- Blade height: 107mm.
- Depth to fit: 88mm
- Glazing thickness: 28mm (Typical)
- Visual free area : 77%.

Finishing

Natural anodised: 15 to 22 micron.

Other shades possible.

Powder coated in any RAL finish: 60 – 80 micron.

Manufacture

- Made to measure.
- Bar length profile for self assembly.
- A reinforcement profile carrying extra blade supports is fitted when the width of the louvre is > 700mm.
- Fibreglass insect mesh fitted to the back as standard

Options

- Aluminium water drainage profile can be fitted at the bottom of the louvre.

Fixing

- With glazing beads. Use glazing spacers.

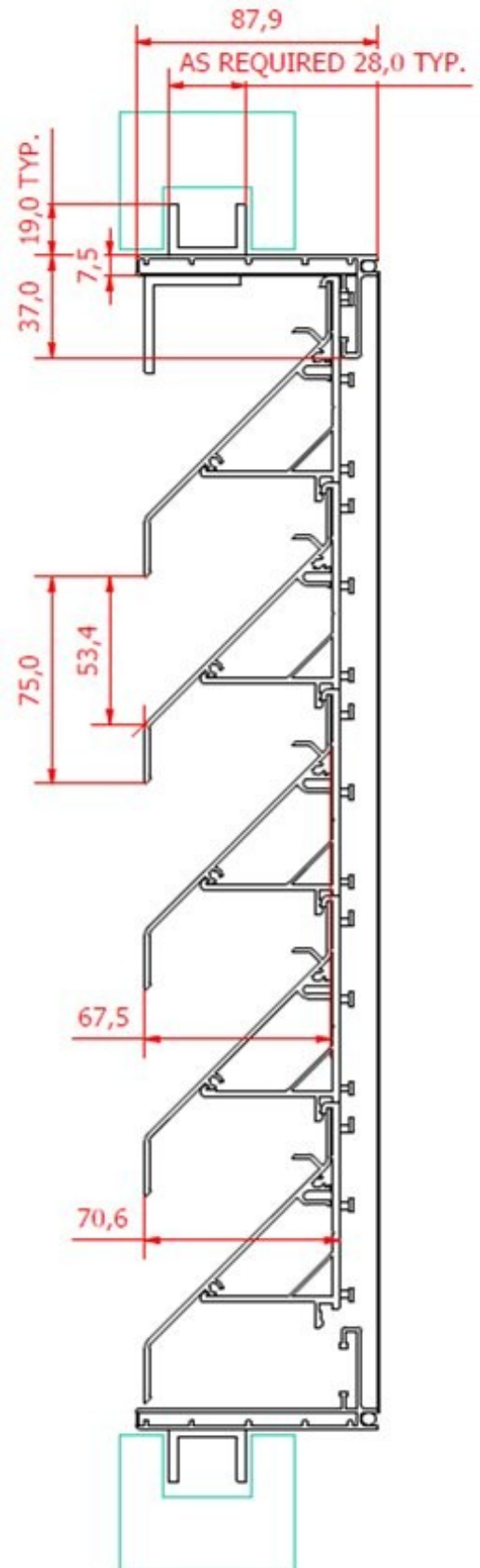



Surface Mounted Louvre LLS75-SM

Type

Surface Mounted Louvre with a Blade Pitch of 75 mm.

Technical details

- Aluminium blade profiles are clipped into aluminium blade support clips.
- Blade pitch: 75mm.
- Blade height: 53.4mm.
- Depth to fit: 88mm.
- Visual free area : 77%.
- Profile thickness: Minimum 1.5mm

Finishing

Natural anodised: 15 to 22 micron.

Other shades possible.

Powder coated in any RAL finish: 60 – 80 micron.

Manufacture

- Made to measure.
- Bar length profile for self assembly.
- A reinforcement profile carrying extra blade supports is fitted when the width of the louvre is > 700mm.
- A fibre glass insect mesh is fitted to the back as standard
- Stainless Steel and Gas meshes can be fitted as an option

Options

- Aluminium water drainage profile can be fitted at the bottom of the louvre to ensure better water tightness.

